

國立清華大學 105 學年度碩士班考試入學試題

系所班組別：工科與系統科學系 乙組

考試科目（代碼）：流體力學 (2503)

1. 解釋名詞 (30%)

- Lagrangian Method
- Eulerian Method
- Streamline, Pathline, Streakline
- (a) What is the Bernoulli equation?
(b) 應用 Bernoulli equation 的假設為何?
(c) 以 pressure 的觀點解釋 Bernoulli equation 內每一項
(d) 以 head 的觀點解釋 Bernoulli equation 內每一項
- Fully developed and developing
- Major loss and Minor loss
- boundary layer thickness and momentum thickness

2. (20%)

- (1) 描繪 Moody Diagram
- (2) 說明摩擦係數與壓降的關係
- (3) 說明層流與紊流的流動阻力與牆壁粗糙度的關係

3. (20 %)

Consider fully developed flow between two infinite parallel plates separated by distance h , with the top plate moving and the bottom plate stationary as shown below. The flow is steady, incompressible, and two-dimensional in the xy -plane. With the aid of dimensional analysis, determine the x -component velocity u as a function of viscosity μ , top plate velocity V , distance h , density ρ , and distance y .

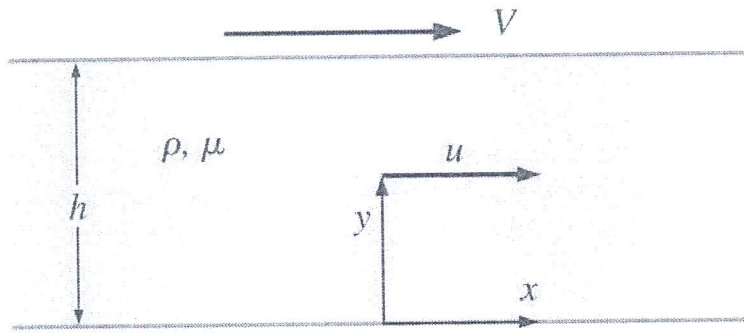

4. (30 %)

Develop the differential equation for conservation of linear momentum (i.e. Navier-Stokes equation) in cylindrical coordinates by applying the control volume method to an infinitesimal control volume of dimensions $r d\theta, dr, dz$.

(σ is the normal stress and τ is the shear stress)

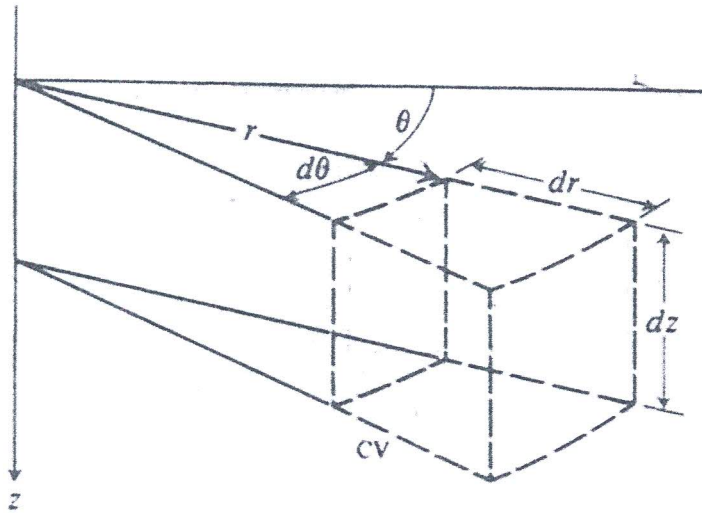

[Hint]

$$\sigma_{rr} = -p + 2\mu \frac{\partial v_r}{\partial r}$$

$$\sigma_{\theta\theta} = -p + 2\mu \left(\frac{1}{r} \frac{\partial v_\theta}{\partial \theta} + \frac{v_r}{r} \right)$$

$$\sigma_{zz} = -p + 2\mu \frac{\partial v_z}{\partial z}$$

$$\tau_{r\theta} = \tau_{\theta r} = \mu \left(r \frac{\partial}{\partial r} \left(\frac{v_\theta}{r} \right) + \frac{1}{r} \frac{\partial v_r}{\partial \theta} \right)$$

$$\tau_{\theta z} = \tau_{z\theta} = \mu \left(\frac{\partial v_\theta}{\partial z} + \frac{1}{r} \frac{\partial v_z}{\partial \theta} \right)$$

$$\tau_{rz} = \tau_{zr} = \mu \left(\frac{\partial v_r}{\partial z} + \frac{\partial v_z}{\partial r} \right)$$